

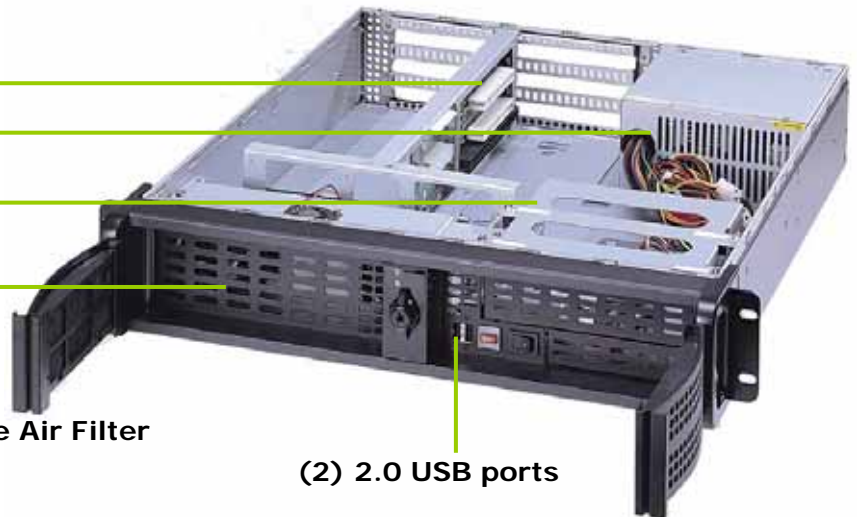

**2U Rackmount Chassis with (1) 5.25" and (2) 3.5" Drive Bays, with 4-slots PICMG Butterfly Backplane, supports Full Size SBC, with Environmental Monitor Board**

**4-Slots PICMG Backplane**  
**Supports PS/2 Size Power Supply**  
**Brackets for (1) 5.25", (1) 3.5" drive and (1) internal 3.5" drives**  
**(2) 6cm Ball Bearing Fans and extra space for one additional fan**



**Latched Front Doors and Replaceable Air Filter**

**(2) 2.0 USB ports**

## Introduction

The **RCK-203BA** 2U Rack mount Chassis provides a classy and resourceful solution for a variety of Industrial applications using Full Size SBC through a (4) slot PICMG butterfly backplane. **RCK-203BA** offers one 5.25" and two 3.5" shock resistive drive bays. Two levels temperature management relies on two ball bearing 6cm fan that provide excellent cooling and System Environmental Monitor that warns users when the system temperature is above normal. One extra space for optional additional fan is provided for more heat sensitive application. **RCK-203BA** offers two 2.0 USB ports and supports standard PS/2 ATX Power Supplies

## Features

- Standard 2U 19" Rackmount Chassis
- Heavy Duty Steel with Ni plating
- Lockable front doors with air filter to protect drives
- 5.25", (1) 3.5" FDD, (1) 3.5" internal HDD drive bays with shock-resistant drive brackets
- Two USB 2.0 ports on front panel
- Supports PICMG 1.0/1.3 Full Size SBC
- PICMG 1.0 Backplane with (4) PCI slots
- PICMG 1.3 Backplane with (2) PCIe x1, (1) PCIe x16 and (1) PCI
- Supports Full Length PCI Expansion
- System Environmental Monitor
- Extra space for one additional 6cm fan



## Mechanical Drawing

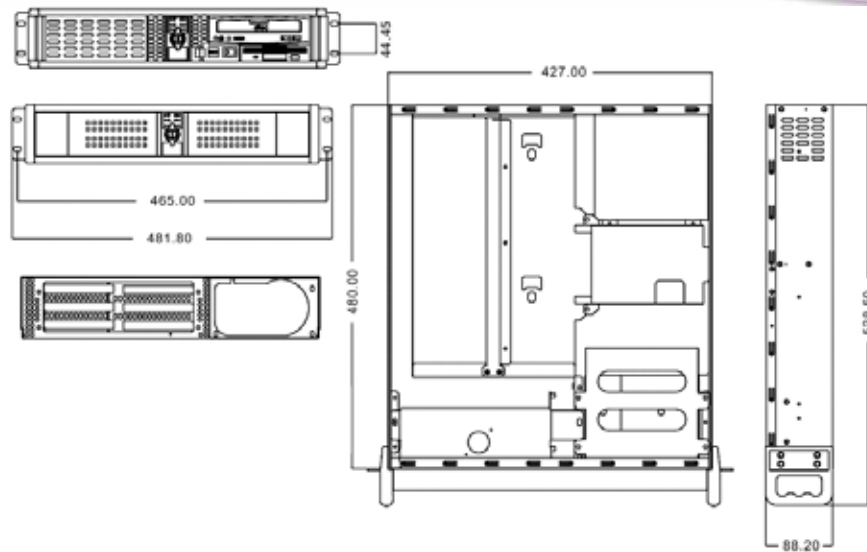

### Construction

- Zinc-Coated Steel with Aluminum Alloy front bezel

### Color

- Black

### Board Support

- Full Size SBC

### Drive Bays

- 5.25" and (1) 3.5" external drives and (1) 3.5" internal drives

### Expansion

- 4-slots PICMG 1.0/1.3 butterfly backplane

### Power Supply

- Supports PS/2 size power supply

### Cooling System

- (2) 6 cm and one extra space for additional fan
- Environmental monitoring board.

### Ports

- (2) USB ports on front panel

### Switches

- On/Off Switch and Reset Switch

### Indicators

- LED for Power ON/OFF, HDD, Fan & Alarm

### Dimensions

- 427 (W) x 480 (D) x 88.2 (H) mm
- 16.8 (W) x 18.9 (D) x 3.5 (H) inches

### Operating Temperature

- 0~55 °C

### Net/Gross Weight

- 8.4Kg/12Kg

## Ordering Information

|                           |  |
|---------------------------|--|
| RCK-203BA<br>-0604PA      | 2U chassis for ATX motherboard with (1) 5.25", (1) 3.5" FDD, (1) 3.5" Internal drive bays and 4 PCI slot PICMG backplane |
| RCK-203BA<br>-0604PA-400W | RCK-203BA with 400W ATX PS/2 power supply and 4 PCI slot PICMG backplane   |
| RCK-203BA-501P            | 2U Chassis with PICMG1.3 butterfly backplane and without power supply  |
| RCK-203BA<br>-501P-400W   | 2U Chassis with PICMG1.3 butterfly backplane and 400W PS/2 power supply  |
| MT-SR01                   | Optional slide rail for RCK-203BA  |